

ALKAR Brine Chiller

FASTER, MORE UNIFORM CHILLING THAN AIR COOLERS



SHORTER COOLING TIME

- Faster turnaround
- Higher yields (no cooler losses)
- Reduce bacteria growth
- Increase shelf life

IMPROVED PRODUCT QUALITY

- Consistent yields
- No wrinkling of natural or collagen casings
- Eliminates condensation in coolers
- Consistent peelability
- Consistent sliceability

LOWER OPERATING COSTS

- Lower energy costs
- Less shower water usage
- Higher production output
- Lower in-process inventory
- Better floor space utilization

Cooling Times: Brine vs. Blast vs. Holding
Boneless Ham, 7 lb., Pressed, 10" x 6" x 3.5"

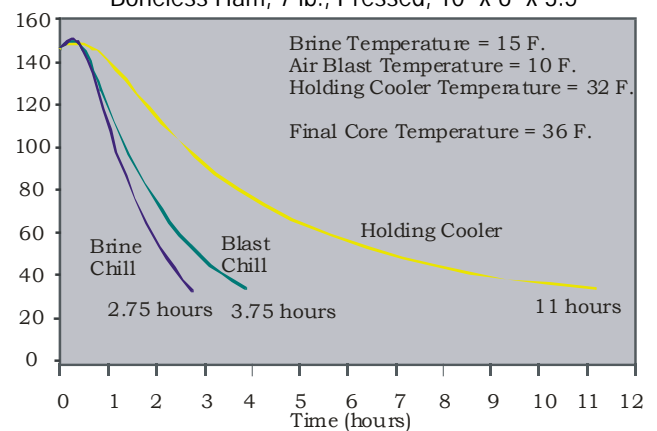

Cooler Shrink Comparisons
Retail Boneless Hams, Permeable Fibrous Casings

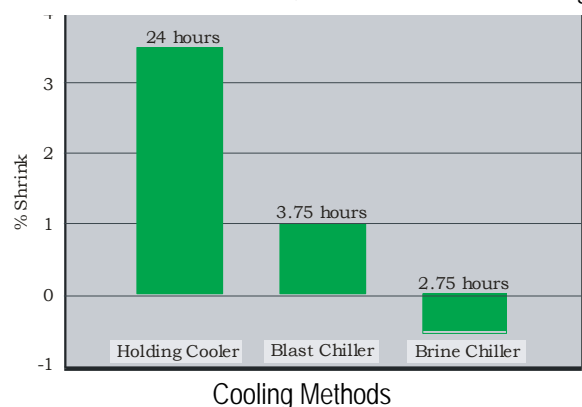

ALKAR Brine Chiller

FASTER, MORE UNIFORM CHILLING THAN AIR COOLERS

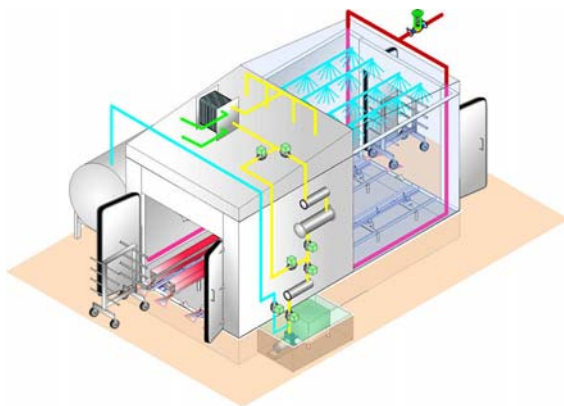
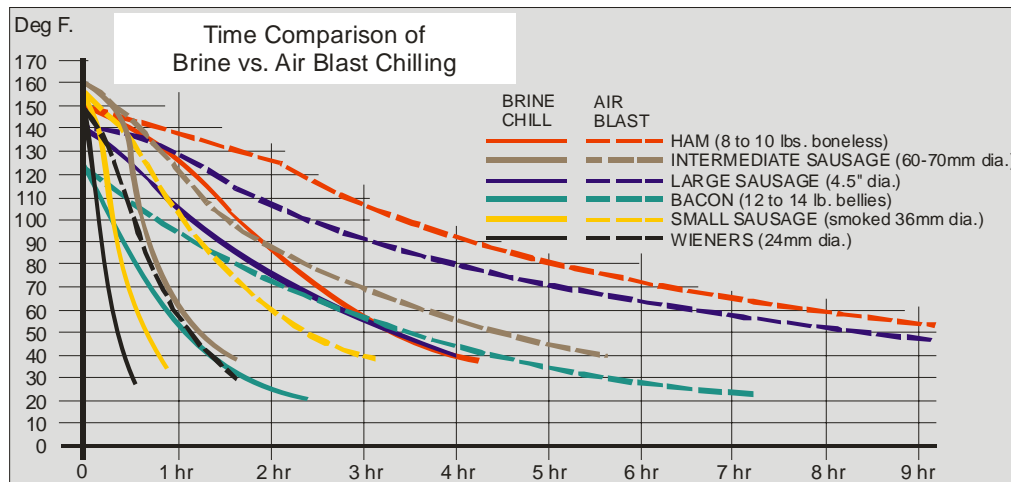

INCREASE CAPACITY / LESS FLOOR SPACE

- Rapid brine chill requires significantly less space than air coolers
- Typical 2:1 ratio between oven size and brine chiller

REDUCED LABOR / REDUCE INVENTORY

- Pack off cook-in-bag products directly into shipping carton
- Increase turns, process, and package in 1 day

WALKING BEAM CONVEYOR

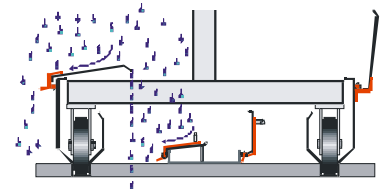
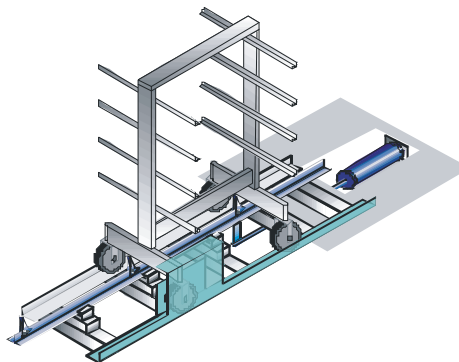
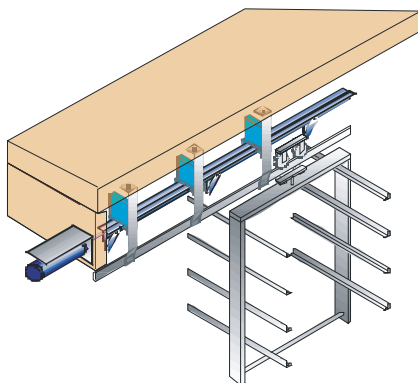

Patented wheel shield allows use of common trucks without contaminating brine

ELIMINATE VARIABLE COOLER SHRINK

- Optimize pump because of reduced variation