

# ALKAR J-Con CPS

## COMPLETE AUTOMATION FOR HOT DOGS AND SMOKED SAUSAGE

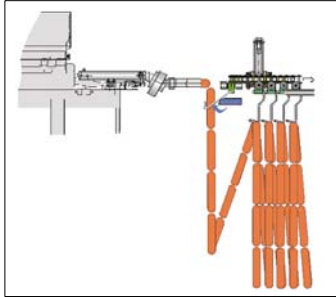
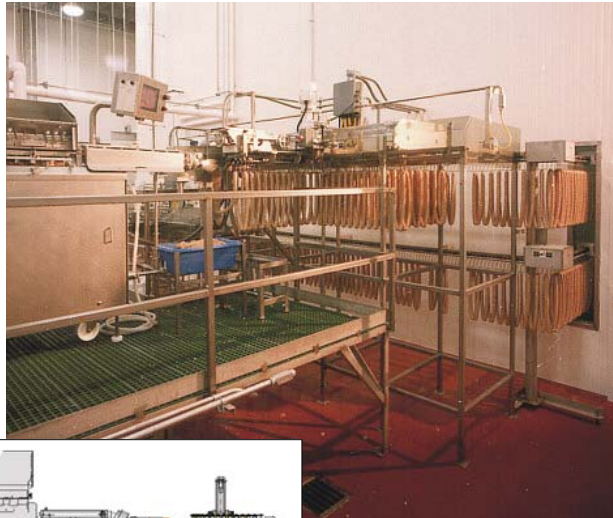

Stickless system directly links on to cook/chill chain

J-Con buffer ensures continuous chain speed while linker cycles on/off to change casings

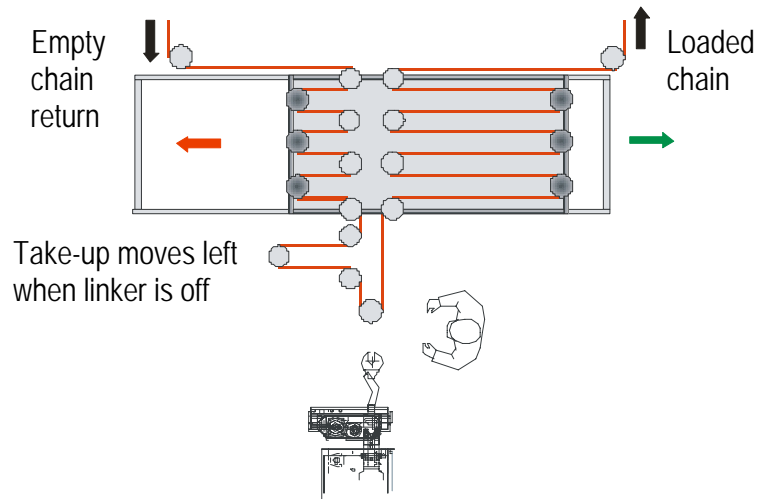

## UNLIMITED CASING LENGTH

- NL 21 currently handles 21" (533.4 mm) strand 225 feet (68.6 m)
- Reduce rework; fewer ends, fewer tie-offs
- Increase linker uptime; more capacity, better consistency

## REDUCE LABOR

- Two operators; two NL 21 linkers
- One operator; two peelers
- Zero load / unload labor
- Reduce food safety risks

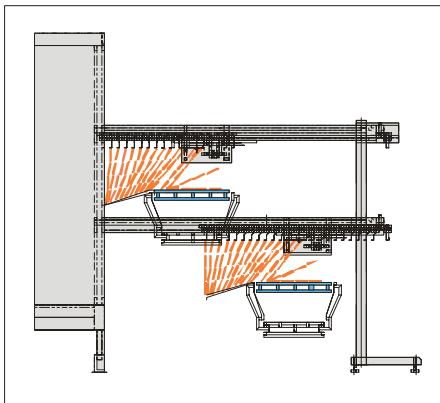

# ALKAR J-Con CPS

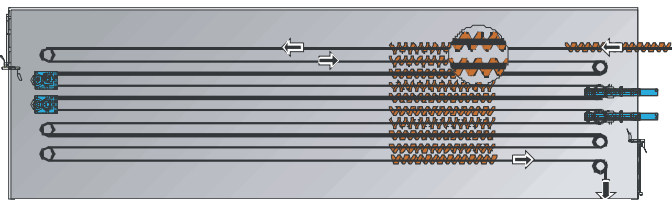
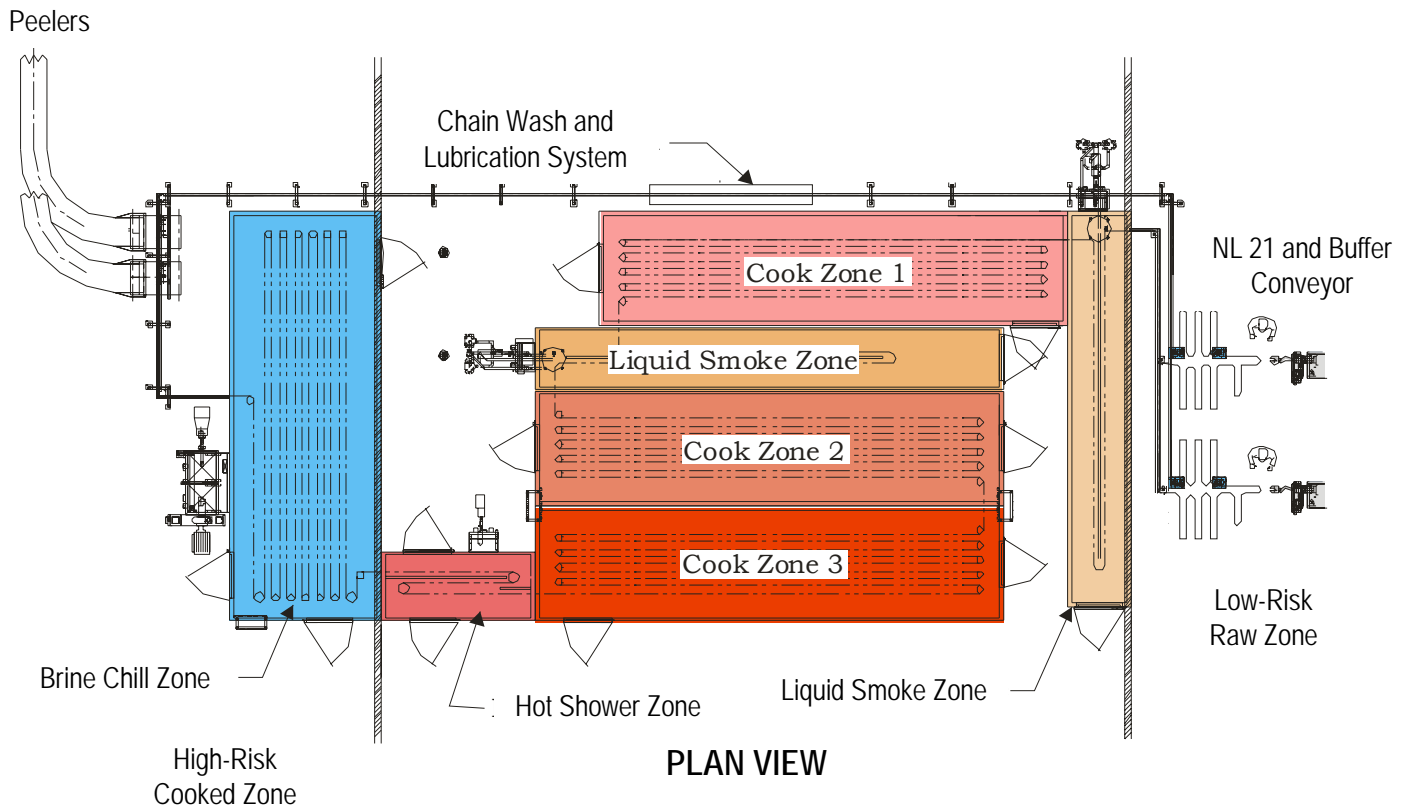

## FLEXIBLE LAYOUT

- Densely loaded zones, horizontal Serpentine product flow
- Orient zones in different directions
- Pre-rinse and secondary liquid smoke zones

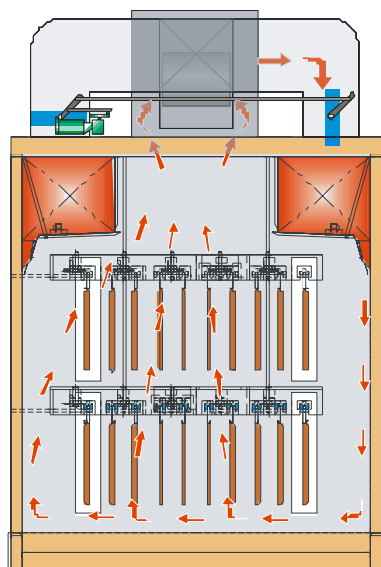

## SUPERIOR CONSISTENCY

- Uniform spacing eliminates "touchers"; ensures consistency
- Uniform color, temperature, yield
- Potential for unlimited casing length; lowers rework

